

時の流れ - 建築・防災の教育と研究をふりかえって

The Flow of Time – In Retrospect of Education and Research on Earthquake Engineering and Disaster Mitigation of Built Environment

中島 正愛

Masayoshi NAKASHIMA

Synopsis

This article presents a summary of my public life as a researcher, educator, and manager for the past forty years. I was engaged in research primarily for four topics, namely, (1) Extension of online test (hybrid simulation), (2) Damage to 1995 Kobe earthquake and re-evaluation of the ductility capacity of steel structures, (3) Performance evaluation of protective members and systems, and (4) Applications of new materials to building structures. I taught at Kobe and Kyoto Universities, supervised 93 students (for bachelor theses), 64 students (for master theses), 29 students (for doctoral theses), and 35 post-doc students, and worked with 31 guest scholars. I served as Inaugurating Director of E-Defense, NIED (National Research Institute for Earth Science and Disaster Resilience), Director of DPRI, President of Architectural Institute of Japan (AIJ), and President-Elect of International Association for Earthquake Engineering (IAEE).

Keywords: Kyoto University, Kobe University, Lehigh University, DPRI, E-Defense, Architectural Institute of Japan, Cabinet Office of Japan

1. Introduction

I retired from Kyoto University on March 31, 2017, having closed forty-some years of professional life as a student, educator, and researcher. I enrolled in Kyoto University in 1970 and spent seven years in Kyoto as an undergraduate and graduate student. After finishing my master course, I fled to the United States of America, having lived in Bethlehem, Pennsylvania, for a few years as a doctoral student of Lehigh University. After graduation, I was luckily hired by Building Research Institute (BRI) of then the Ministry of Construction. Later, I moved to academia, having taught at Kobe University and Kyoto University. During the tenure, I also worked (part time) for the National Research Institute for Earth Science and

Disaster Prevention (NIED) and the Cabinet Office of Japan (COA).

In this article, I would like to present an outline of my research for the past four decades, a summary of my activities as an educator and an administrator, and an excerpt of my service to various professions.

2. Research Activities

2.1 Summary of Research Topics

Regarding my life as a researcher, I count myself extremely lucky, because I have always been able to independently identify the subjects of my research and plan the methods for pursuing them. In retrospect, my research can be categorized into four subjects, with a few specific topics in each of

them. They are summarized as follows:

- (1) Extension of online test (hybrid simulation)
Experimental Error Growth and Error Control Associated with Online Test in the 1980s; Development of Substructure-Based Online Test in the 1980s and 2000s; Development of Substructure-Based Online Test in the 1980s and 2000s; Development of Real-Time Online Test in the 1990s; Generalization of Online Test in 2000s; Development of Substructure-based Shaking Table Test in late 2000s.
- (2) Damage to 1995 Kobe earthquake and re-evaluation of the ductility capacity of steel structures
Reconnaissance of 1995 Kobe in mid 1990s; Fracture and Performance of Steel Welded Beam-to-Column Connections in 1990s; Reproduction of Collapse Behavior of Steel Members and Systems in 2000s.
- (3) Performance evaluation of protective members and systems
Hysteretic Behavior of Steel Shear Walls using Low-Yield Steel in 1990s; Development of Members and Systems having Self-Centering Capability in 2000; Performance of Functionality in Base-isolated Hospital Buildings in the 2000s and 2010s.
- (4) Applications of new materials to building structures
Bolt-only Structures Using H-SA780 Ultra-high Strength Steel in the 2000s and 2010s; Connection of Steel and Concrete Using SFRCC in the 2000s and 2010s; Development of Slitted Steel Shear walls in the 2000s and 2010s; Naturally Buckling Braces and Braces with Intentional Eccentricity in the 2010s; Sliding Structures for Capping Maximum Shear to Superstructures in the 2000s and 2010s).

Together with my students, post-docs, and research collaborators, I have written a number of technical papers on the research subjects described above. I was able to write a total of 203 papers (consisting of 105 papers in Japanese and 98 papers in English) that have been published in peer-reviewed journals. Most of the Japanese papers were published in Journal of Structural and Construction Engineering of AIJ, all the while I

have co-authored 32 articles in the Journal of Earthquake Engineering and Structural Dynamics, 34 articles in the Journal of Structural Engineering, ASCE, among others.

In retrospect, I see myself engaged in various research topics in accordance with my own interests. This means that I was fortunate enough to be able to work always in environment in which the challenges were understood. It also suggests that I was lucky to have had good, understanding bosses and be surrounded by capable students and post-docs. I hereby express my sincere gratitude to all of them. Occasionally, I introspect that my research outcomes would have been deeper if I had chosen fewer topics to research. Naturally, it is too late now.

In what follows, I present summaries of a few specific topics.

2.2 Experimental Error Growth and Error Control Associated with Online Test

A very interesting structural testing technique, called the “computer-computer online test,” or “pseudo-dynamic test,” and more recently “hybrid simulation,” became a major subject of research in early days of my academic life. The technique was invented by Japanese researchers at the University of Tokyo. Professors Motohiko Hakuno, Hisashi Tanaka, Koichi Takanashi, Tsuneo Okada, Kuniaki Udagawa, and Matsutaro Seki were the original developers of this technique. The idea was to combine quasi-static loading tests with time-history numerical analysis using direct integration. The technique is able to reproduce the earthquake response of the concerned structure in the time domain, with the time axis elongated significantly, as if we were viewing a slow motion video of the shaken structure. To express my sincere appreciation to the originators of this testing technique, I call this “online test” as this was the abbreviated term that those originators used in their early publications.

I was exposed to the online test when I joined BRI and became involved in the US-Japan research projects. I was assigned as a member of the team that was responsible for the test of a full-scale six-story steel building frame (Figure 1). The US-Japan collaboration, called the Joint Technical Coordinating Committee (JTCC), determined that

the online test should be implemented and the frame be treated as a 6DOF model. In the test, a large actuator was installed at each floor level, and a total of seven actuators (including two on the roof) were controlled for the online test. During the course of loading, we noticed that the online test was not necessarily easy when we need to deal with multiple actuators, and learned that three issues needed to be looked into for further advancement of the online test. These issues are: 1) Error Growth and Control, 2) Extension Using Substructuring, and 3) Real-time Online Test.

For 1), the actuator cannot be precisely positioned at the right displacement; such displacement errors (although they were in a range of smaller than 1 mm) are not harmful in conventional displacement-based tests but tend to seriously deteriorate the response in the online test. For 2), considering the concept of online test, we do not have to make the entire structure for the specimen but can fabricate the actual specimen only for the part whose hysteretic behavior is complex, while the rest of the structure can be treated numerically in the computer. For 3), if the actuator is loaded dynamically at the real velocity and the computer can make its calculation fast enough so that the next target displacement is estimated within a very short period of time (say, 1 □s), it would be possible to do the online test at the real velocity. I became engaged in those three subjects for about ten years starting in the mid-1980s. In early days of my engagement, I was with BRI and worked with Dr. Yutaka Yamazaki and Messrs. Takashi Kaminosono and Hiroto Kato, to whom I do extend my sincere appreciation. I also worked on this subject after I moved to Kyoto, with my students and post-docs.

The online test, strangely renamed “hybrid simulation,” attracted the attention of many researchers starting at the turn of the century, and the papers I wrote in 1980s and 1990s have been referred to in various journal articles (Nakashima and Kato, 1988; Nakashima and Kato, 1989; Yamazaki et al., 1989). I received multiple awards for my research on the online test, and this was because the subject became popular after I wrote the papers. I count myself very lucky as, when I myself was working on this subject, I had no idea at all how famous the subject was to

become.

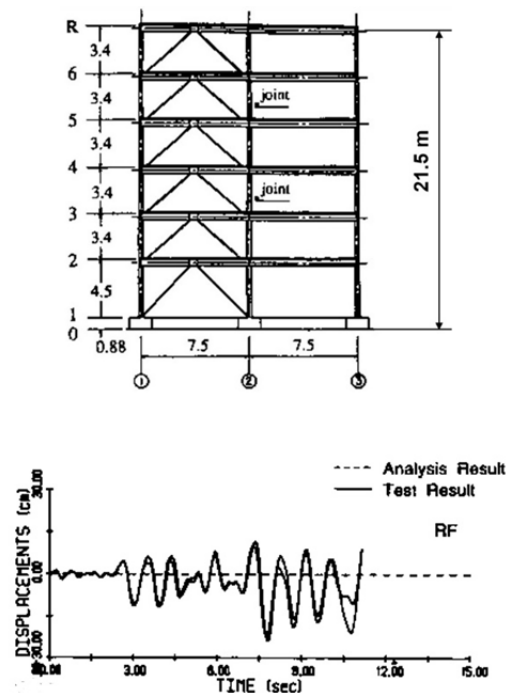

Figure 1. A full-scale six-story steel braced frame tested at BRI as part of US-Japan Joint Research Utilizing Large-Scale Testing Facilities. The upper drawing shows an elevation of the frame whose height is 21.5 m. The lower drawing shows a displacement time history of one of the test series. To simulate the ten second response, it took about five days because of intensive observation after each major step of loading.

2.3 Development of Substructure-Based Online Test

The idea of incorporating the concept of substructuring into the online test sounds very natural. It was indeed advocated from the onset of the online test. The problem that had blocked this application was the numerical instability of the direct integration that was employed in the computation of the equations of motion during the online test. In the nature of the online test, the displacement in the next step must be estimated explicitly before the actuator begins to move, and for this reason the central difference method, the most popular in the family of explicit integration methods, was adopted in the online test. When the degrees of freedom increase, which shall occur when we add the numerically-solved substructure with many degrees of freedom, the method has

difficulties in maintaining numerical stability.

To overcome this obstacle, I came up with a method called the Operator-Splitting (OS) method. This method was explicit, but ensured unconditional stability, and it was found to be very suitable for the online test with substructuring. This idea was nurtured after my conversation with Professor Tom Hughes, a legendary giant in the field of computational mechanics, at his office at Stanford in 1985. An old friend of mine, Professor Helmut Krawinkler of Stanford University, kindly set up my meeting with Professor Hughes.

I was able to demonstrate the strength of this method through a joint project involving BRI, Kajima Corporation, and Sato-Kogyo Corporation, which was conducted in late 1980s (Nakashima et al., 1990; Nakashima, Ishida, and Ando, 1990). We conducted three tests for a three-story base-isolated building structure, one for the entire structure using a shaking table, another for the entire structure using the conventional online test, and last utilizing the substructuring technique in which only the base-isolated system was tested and the rest was handled in the computer (See Fig. 2). Three tests were conducted successfully. After I moved to Kyoto University, I engaged again in further development of the substructuring technique with my students.

2.4 Development of Real-Time Online Test

One of the greatest values of the online test was its unique feature of quasi-static loading, whereby we can conduct the test on larger scales and observe the progress of damage most closely. This feature also makes it handy for many researchers to implement the test. Note that dynamic actuators are commonly far more expensive and significantly less powerful (in terms of the force and stroke capacities) than quasi-static actuators. Nonetheless, once we have to deal with structures whose parts are strongly velocity-dependent in their behavior, we cannot obtain reasonable responses unless they are loaded at the real speed; hence, expanding the idea of the online test to conduct them in real time was thought to be a reasonable idea.

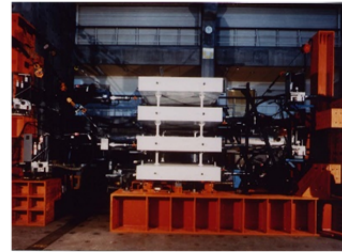
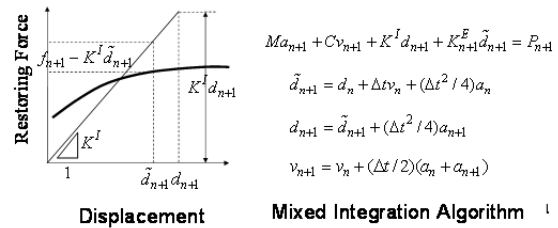

On-Line Test for Overall Structure

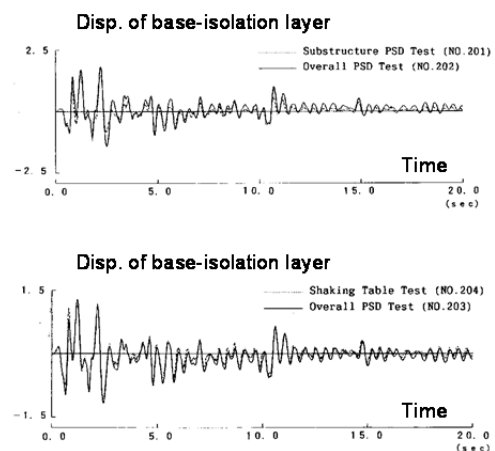

Figure 2. A few shots related to the development of online test with substructuring techniques. The top shows the basics for the solution of equations of motion using the Operator-Splitting method by which it was made possible to run the online test with many DOFs. The middle picture shows the test for a three-story base-isolated structure. Three types of test were exercised, i.e., the shaking table test on the entire structure, the online test also on the entire structure, and the substructure online test when the test was applied only to the base-isolation device. The bottom shows the comparison in response among the three tests. The correlation was very good, I trust.

It was the early 1990s when the technology of digital signal processing (DSP) became available in the market. I became involved in the development of a technique such that the test would be conducted in real time using DSP, called the “real-time online test.” Fortunately, BRI had owned an early-day dynamic actuator since the 1980s. With an algorithm I named “staggered integral,” I, together with Mr. Hiroto Kato of BRI

and graduate students of Kobe University, overcame the problem of the time delay associated with the prediction of future displacements, and conducted a test for a simple base-isolated building structure in which a viscous damper was installed.

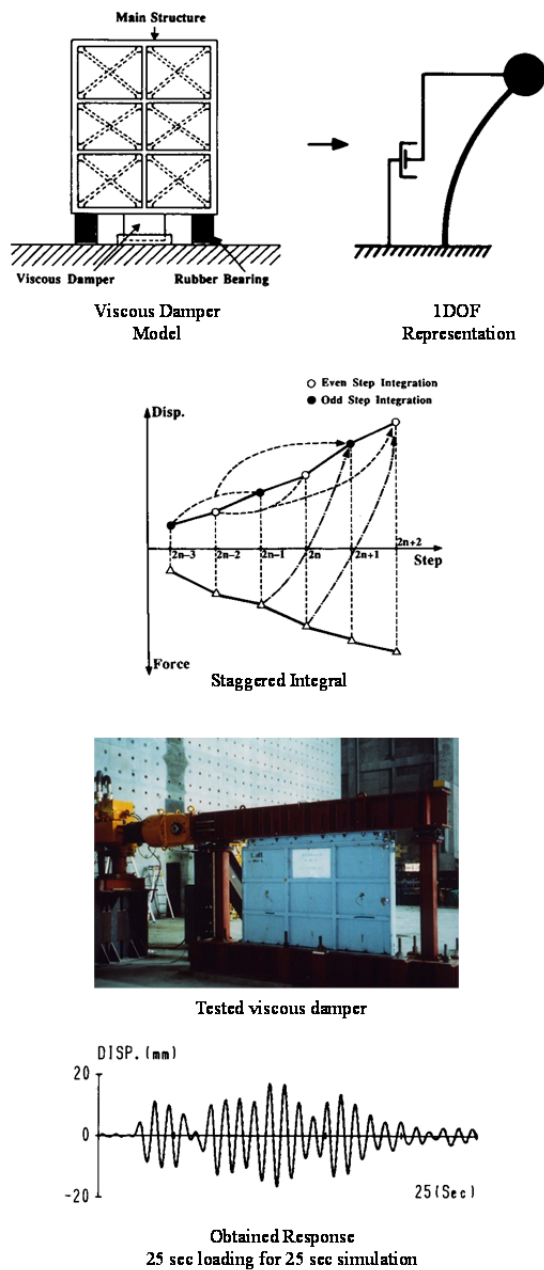

Figure 3. Real-time online test applied for a base-isolated structure in which a viscous damper is tested online and in the real time (Top drawings). To avoid a time lag, a staggered integral method was invented (second top drawing). The test, applied to a viscous damper (second bottom picture), was successful in the achievement of real-time simulation (bottom drawing).

The viscous damper was treated as the tested portion, while the rest was handled in the computer (Figure 3).

I re-visited this problem after I moved to DPRI, Kyoto University, as DPRI acquired a dynamic actuator system after the 1995 Kobe earthquake. The time difference was just a few years, but the advancement of DSP was very fast. Using the latest version of DSP, I and my students in Kyoto University were able to simulate a series of real-time online tests applied to a base-isolated building structure equipped with high-damping rubber bearings. The specimen was very handy as it recovered to its original state in about fifteen minutes even after sustaining many cycles of inelastic responses. This property was indeed a great help because the loading was very sensitive with various parameters, and in numerous instances the test was forced to stop half-way through and unsuccessfully. The good responses that were obtained and eventually appeared in journals followed numerous erroneous responses. Two papers that described the real-time online tests were published in the *Earthquake Engineering and Structural Dynamics (EESD)*, one in 1992 and the other in 1997 and, fortunately, have been cited by many recent papers (Nakashima et al., 1992; Nakashima and Masaoka, 1999).

2.5 Fracture and Performance of Steel Welded Beam-to-Column Connections

After the disclosure of damage (fracture) of welded beam-column connections in the 1995 Kobe earthquake, the Steel Committee of AIJ's Kinki Branch, headed by Professor Kazuo Inoue, then of Osaka University, established a comprehensive research project to identify the problems and offer feasible solutions. Seven universities located in the Kinki area joined the project and shared responsibilities for the planned tests, including a total of nearly one hundred specimens of welded beam-column connections. I formed the Kyoto University team with Professor Kiyotaka Morisako of Kyoto Institute of Technology and Professor Keiichiro Suita of Kyoto University, and performed tests on fourteen specimens having three types of connection/welding details. One of the unique features of the tests conducted by our team was that a dynamic actuator was used, and for some

specimens, dynamic loading (testing at a realistic velocity experienced during earthquake responses) was adopted instead of more conventional quasi-static loading. The advantages of no weld access hole detail relative to the conventional weld access hole detail were demonstrated from the tests, and dynamic loading was found not to necessarily reduce the ductility of welded beam-column connections (Figure 4).

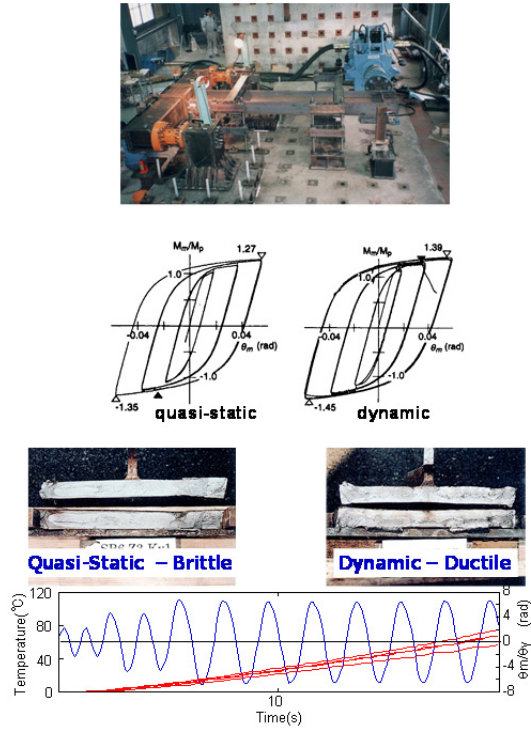

Figure 4. We looked into the effect of rate-of-loading on the performance by the application of dynamic loading to the connection (top). The two hysteresis loops (second top) show the results of quasi-static and dynamic loading. If anything, the dynamic loading exhibited more ductile behavior than the quasi-static loading. In fact, the fractured surfaces were more brittle in quasi-static loading (second bottom, left) than in dynamic loading (second bottom, right). A most plausible reason was the significant rise in temperature (bottom) during dynamic loading. These results were published as an article of ASCE Structural Journal. Fortunately, the article was awarded “ASCE Moisseif Award”.

For a long time, it had been believed that fast-rate loading would make the steel brittle and therefore decrease its ductility. What happened

was that the energy dissipated by cyclic plasticity was transferred to thermal energy, which in turn raised the temperature in the plasticized region significantly. Not also that steel is known to be more ductile at higher temperatures (Nakashima et al., 1998; Suita et al., 1998). A paper written on this subject was published in the ASCE Structural Journal, and very, very fortunately, the paper was chosen to receive the ASCE Moisseiff Award in 2000. It was a total surprise when I received a letter from ASCE that told me that my paper had been chosen for this award. I felt very lucky and also honored.

2.6 Hysteretic Behavior of Steel Shear Walls using Low-Yield Steel

I became engaged in research on passive control and dampers in the 1990s when the Japanese steel industry developed so-called low-yield steel (Nakashima, Akazawa and Igarashi, 1995; Nakashima, Akazawa and Tsuji, 1995; Nakashima, 1995). Dr. Mamoru Iwata, then a director in Nippon Steel, kindly offered me an opportunity to collaborate with them regarding the use of low-yield steel for a hysteretic damping device. Using the steel as a shear panel, we conducted a series of tests for the quantification of their hysteretic behavior.

What was made very clear was that low-yield steel has significant strain-hardening under cyclic loading, and with many cycles in the same amplitude, the strength more than doubled. I became interested in that particular behavior and, together with my students, came up with a model in which significant isotropic type of hardening was explicitly incorporated (Figure 5). Although use of low-yield steel remains limited in actual practice, I trust that this steel, particularly when combined with steel having a different strength, would benefit us in the development of new structural systems and components. In fact, I re-visited this type of steel later in conjunction with a new type of brace.

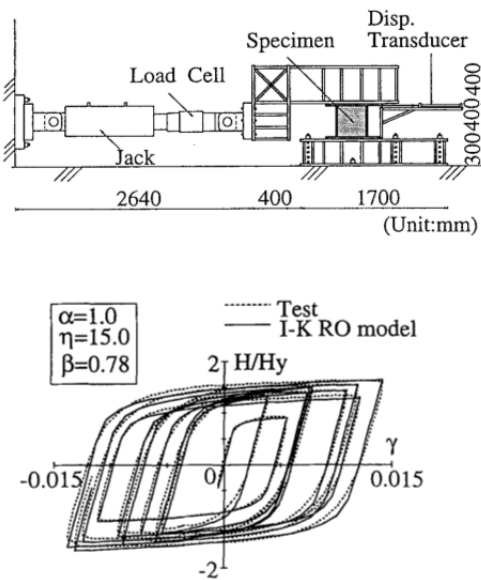

Figure 5. A then new type of steel, named low-yield steel, whose nominal yield stress of 100 MPa, was tested to examine if such steel can be used as a material of hysteretic damper. The steel was used as a steel panel, and its in-plane behavior was tested using a quasi-static loading system (top). The hysteresis loops (bottom) exhibit very conspicuous isotropic-type strain hardening. Later, we developed a hysteresis model that can simulate such behavior.

2.7 Performance of Functionality in Base-isolated Hospital Buildings

During my tenure as Director of E-Defense, I served as the principal investigator of several projects sponsored by Ministry of Education, Culture, Sports, and Science and Technology (MEXT). One of them was “Maintenance of functionality of medical facilities immediately after strong shaking”. The importance of this issue is very obvious. To provide quantitative data on this issue, a team headed by Dr. Eiji Sato of E-Defense and joined by my students, conducted a series of tests for a four-story, base-isolated RC building in which various medical facilities were installed as realistically as possible (Figure 6). Various medical facilities such as a CT scanner were also installed in the building. Note that a new CT scanner is much more costly than the entire test of the RC building, but very fortunately multiple hospitals kindly donated their old ready-to-discard appliances.

The results are very informative, indicating that under long-period ground motion, the base-isolated

hospital moved with large displacements but the level of accelerations remained low so that no structural damage occurred. However, appliances that were equipped with casters (to ease mobility) moved vehemently under such long-period ground motion, collided seriously with other appliances, and were made dysfunctional. That observation was shared with people engaged in medical activities, who recognized serious needs for measures to avoid such situations. The easiest solution to this is simply to lock the casters and prevent motions. From conversations with medical professionals, we discovered that locking the casters at all times is not feasible in ever-busy hospitals. This is an example of the contradiction that efficiency in normal life can be a source of further troubles during disasters.

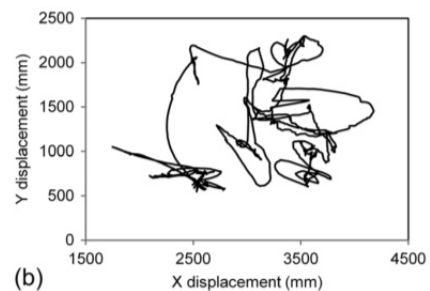

Figure 6. E-Defense test applied to a four-story base-isolated RC hospital. The top picture shows the test specimen in which a variety non-structural components, contents, and medical appliances are installed. The two pictures (top right) show the setup of a nurse station and an operation room. Medical appliances equipped with casters were found to move vehemently when the base-isolated structure is subjected to long period ground motion. The bottom drawing shows the moving orbit of a cardioverter defibrillator in the operation room, which moved more than 3.0 m.

As a byproduct of the study noted above, we also spent some effort to reduce the floor acceleration using semi-active control with MR dampers. We developed a new control strategy to reduce the movement of medical appliances with casters even when subjected to long-period ground motions (Sato et al., 2011; Shi et al., 2014; Shi, Kurata and Nakashima, 2014).

2.8 Development of Slitted Steel Shear walls

Slitted steel shear walls were the special subject of Professor Toko Hitaka. She worked as an associate professor in my group between 2007 and 2010. Her original work was to apply many slits vertically in an otherwise monolithic steel plate, resulting in a slitted steel shear wall.

The slits change the mode of yielding and failure of the panel from a shear mode to a flexural mode by which the post-yielding behavior was made more stable with larger energy dissipation. She and our students tried to extend this slitted shear wall concept, more specifically, to use thinner plates to reduce the weight so that the slitted shear wall can be adopted for seismic rehabilitation. To avoid the buckling inherent to thin plates, we used wood panels (far less heavy than steel panels) and sandwiched the slitted shear wall by a pair of the wood panels (Figure 7).

Wood is much more flexible in the thickness direction than steel, and can accommodate out-of-plane deformations (by buckling) that some parts of a steel shear wall must sustain during large in-plane deformations, so that we do not have to worry too much about the clearance between the shear wall (inside) and the wood panel (outside). We were able to develop light-weight shear walls that can dissipate large energy by inelastic actions.

In the course of testing the slitted steel shear walls, we discovered a beautiful and very consistent out-of-plane deformation of the part (named the link), enclosed by two adjacent vertical slits in the slitted shear wall as shown in Figure 8. The instant when the link buckles and begins developing the out-of-plane deformation was found to be controlled by the width of the link, that is, a wider link buckles earlier than a narrower link. I thought that, by arranging links with various widths, it may be possible for the slitted shear wall to serve as a device to estimate the maximum lateral drift

that the shear wall would have experienced (Figure 8).

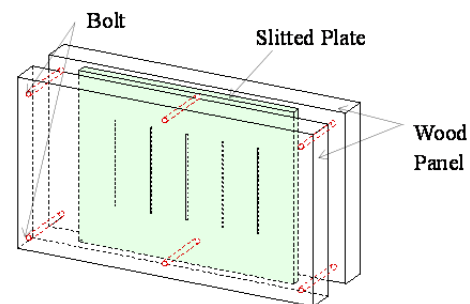

Figure 7. A steel wall with vertical slits is used as a hysteretic damper. Although the vertical slits change the mode of deformation from overall shear deformation to a series of flexural deformations and make the wall more energy dissipative, out-of-plane buckling yet occurs unless the wall is very thick. To delay such buckling even for thin walls, we enclose the wall by wood panel from both sides (top). The bottom picture shows a demonstration test of a three story planar frame in which such walls are installed. The walls are indeed energy dissipative.

My students and I carried out a series of tests using such slitted shear walls featuring with different widths, and demonstrated that the proposed shear wall can not only serve as an energy dissipation element but as an device to sense and record the maximum lateral deformation that the shear wall (and eventually the story drift) sustained during an earthquake (Kurata et al., 2015; He et al., 2017).

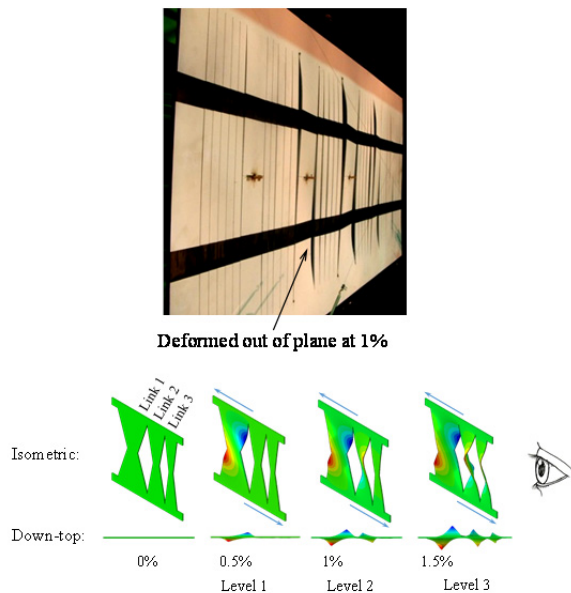

Figure 8. We developed a slitted steel wall having various widths between the adjacent links such that the wall also serves as a device to detect the maximum lateral deformation (drift) sustained by the wall. As shown in the bottom drawing, when no buckling is observed by any link, the maximum drift angle shall not be greater than, say, 0.5%. When the thickest link is buckled and others not, the maximum drift angle shall be, say, between 0.5 and 1.0%, and so forth. The devised wall has a dual function of energy dissipater and monitoring instrument.

We submitted a first paper on this subject to EESD (Earthquake Engineering and Structural Dynamics) and, fortunately, the paper was accepted for publication. I still remember the comment from one reviewer, who said: “The paper presents a very complete treatment of the subject, with an appropriate balance between practical considerations, use of basic mechanics, use of advanced FEA, and experimental work. In thinking about a host of technical issues that came to mind as potential practical and technical issues from the work described, I decided that those were immaterial as this is an extremely clever and original paper. Thus I think that the paper can be printed as is”. Over the last three decades, I have received numerous review comments on papers that I and my students have submitted to various journals, but the comment I received for this paper was the most memorable and honorable in a lifetime of being reviewed.

2.9 Naturally Buckling Braces and Braces with Intentional Eccentricity

I revisited brace research after receiving a post-doc who had worked on steel brace behavior under the supervision of a long-term friend of mine, Professor Charles Roeder of the University of Washington. During this period, we also worked on the use of high-strength steel for building construction. I had an idea about a steel brace in which such high-strength steel was adopted. In the development, we intentionally combined high-strength steel and the other extreme, low-yield steel, in one section as in Figure 9, and furthermore initial eccentricity was applied.

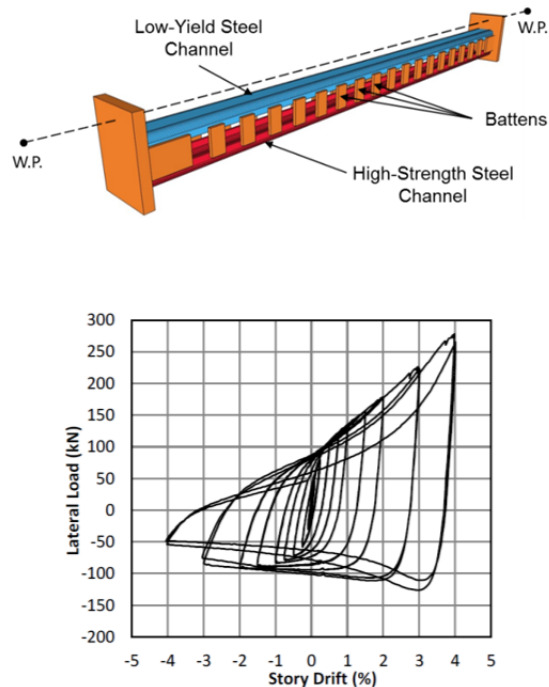

Figure 9. NBB (Naturally Buckling Brace) is a brace in which a channel section made of low-yield steel and another channel section made of high-strength steel are connected by battens to form a cross section (top). NBB is intended to reduce the initial stiffness, to start dissipating energy earlier, to increase the second stiffness (after first yielding), and to delay the fracture. The hysteresis loops shown in the bottom drawing show the behavior that we intend for NBB to sustain.

In the brace, the low-yield part yields earlier and begins dissipating energy, while the high-strength part stays elastic and serves as a backbone to keep the brace integrated and the brace’s strains along the length distributed as uniformly as possible.

The brace is characterized by early yielding, a good amount of stiffness after first yielding, and a very large deformation until the yielding of the high-strength portion. We named the brace NBB (naturally buckling brace). In the early stage of development, the ends of NBB were supported by mechanical pins but, out of consideration for practical applications, a pin was replaced by a gusset plate to which NBB was bolt-connected. Fortunately, we were able to achieve the performance that we expected.

Intentional eccentricity also worked reasonably well in terms of early energy dissipation and uniform deformation along the length. Encouraged by this observation, we also looked into the possibility of a conventional brace but with initial eccentricity for the purpose of early energy dissipation and larger ductility. We named the brace BIE (brace with intentional eccentricity). We also adopted gusset plate connections to achieve the pin-end and initial eccentricity. Very fortunately, a series of tests for BIE were found promising. NBB is more energy dissipative and more ductile than BIE, but BIE was also found to be promising in achieving ductility even with conventional braces (Hisao et al., 2016; Skalomenos et al., 2017; Inamasu et al., 2017).

3. Life as Educator

I spent four years as an associate professor at the Department of Environmental Planning, Kobe University. Although the period of my tenure was short, I was very fortunate to be able to interact with quite a few students. Professor Bunzo Tsuji, my boss, generously gave me complete freedom on the research subjects of the students I supervised. I served as the academic supervisor for a total of 35 bachelor's theses and 17 master's theses.

In Kyoto University, I served as the academic supervisor for a total of 58 bachelor's theses and 47 master's theses. I tried my best to recruit good graduate students and post-doctoral fellows from overseas countries. Fortunately, thanks to the scholarship programs offered by MEXT and fellowship programs offered from JSPS (Japan Society for the Promotion of Science), quite a few foreign doctoral students (12) and foreign post-doctoral fellows (23) spent time in my research group at DPRI. In addition, I was able to

invite a total of 31 scholars from overseas regions, most of whom were supported by JPSP invitation programs.

In 1991, the Architectural Institute of Japan (AIJ) established new awards for students, one "Best Bachelor Thesis Award" and the other "Best Master Thesis Award", and gave the awards to fifteen individuals each year for each of the bachelor and master thesis awards. Among the fifteen, three individuals were chosen in the field of structural engineering. I was very fortunate to have had many motivated and hardworking students, both in Kobe and Kyoto Universities. I am happy to report that 13 and 11 students received the best bachelor's and master's thesis awards, respectively.

I served as the doctoral thesis advisor for 29 graduate students and as the research supervisor for 31 post-doctoral fellows. After the completion of study in my group, many of them, a total of 36 as of September 2016, were fortunate enough to have found secured teaching positions. Table 1 shows the number and distribution of those who hold academic positions with respect to the position status and the location of academic institutions. As the former advisor and supervisor, I wish all of them the best of luck in their respective careers.

Table 1. Number of Former Students Holding Teaching Positions

Location Institution	Prof.	Associate Prof.	Assistant Prof.	Total
Japan	1	7	7	15
China	3	3	7	13
Taiwan	0	0	2	2
Korea	0	1	0	1
North America	0	1	1	2
Western Europe	0	3	0	3
Total	4	15	17	36

4. Life as Managing Officer

4.1 E-Defense Directorship

I have managed three research organizations. I had the directorship of E-Defense of National Research Institute for Earth Science and Disaster Prevention (NIED) (from 2004 to 2011), the directorship of DPRI of Kyoto University (from

2011 and 2013), and the presidency of the Architectural Institute of Japan (AIJ) (from 2015 to 2017). E-Defense was founded ten years after the 1995 Kobe earthquake, and I served as its inaugurating director (Figure 10). It was Professor Tsuneo Katayama, then the president of NIED, who asked me to take the director position and saw to my appointment. Expectation to E-defense was naturally high as it was built as a consequence of the 1995 Kobe earthquake disaster and was equipped with the world largest shaking table, which cost nearly 500 million US dollars for construction. Starting from scratch, however, I found it not easy to promptly produce visible, meaningful results to the concerned communities. Thanks to the unfailing support of Professor Katayama and Executive Director of NIED, Dr. Toru Hayama, as well as those working at E-Defense, E-Defense was able to complete over forty full-scale or large-scale shaking tests applied to various kinds of structures during the first few years.



Figure 10. I served as the inaugurating director of E-Defense from 2004 to 2011. The opening ceremony was held on January 18, 2017 to commemorate the tenth anniversary of 1995 Kobe earthquake.

While I was the director, MEXT, the National Science Foundation of the United States (NSF) exchanged a MOU for general research collaboration, and NIED (and E-Defense) and NEES Incorporation (Network for Earthquake Engineering Simulations), which managed NEES activities, exchanged another MOU for specific research collaboration. Under that NEES and E-Defense collaboration, multiple joint projects, including several shaking table tests implemented at E-Defense by US researchers, were carried out.

I served as the coordinator on the Japanese side and was able to create many friendships with US researchers and funding officers. Notably, I thank Dr. Joy Pauschke, the program director for NEES activities, for her continuous interest and support of the collaboration, and Professor Steve Mahin of UC Berkeley who served as the coordinator on the US side.

4.2 Directorship of Disaster Prevention Research Institute (DPRI)

Another unforgettable memory during my tenure as E-Defense director was an imperial visit by Royal Emperor and Empress in September 2007. I was assigned as a guide to their royal highnesses, and had an honor of introducing them, during their half an hour visit, to a shaking table test applied to a three-story RC school building. The test was a success, and their royal highnesses enjoyed the visit. However, the test results were different from what we had anticipated, that is, the shaken building was supposed to fail seriously but it survived with only minor damage. This unexpected outcome gave me a difficulty in explaining the test results, but the generosity and kind understanding of their royal highnesses saved my heart, for which I still feel very grateful.

After five years of service, I stepped down from the E-Defense directorship at the end of March 2011. Immediately after my resignation, I assumed the position of the DPRI directorship (Figure 11). The 2011 Tohoku earthquake took place twenty days before my inauguration as director, and I was heavily occupied for the first few months of my directorship with handling the post-earthquake activities, including reconnaissance, assistance to government agencies and associated communities, and other duties. In addition to those, I and the deputy directors who manage the research operation of DPRI worked together on requests of various budget appropriations to enhance the research activities of the DPRI and ultimately help preserve the welfare of society. I kindly appreciate the enthusiastic supports of my colleague deputy-directors, i.e., Professors Hajima Nakagawa, Manabu Hashimoto, Tomoharu Hori, and Hirohiko Ishikawa. In November 2011, DPRI celebrated its sixtieth anniversary.

In 1952, DPRI started out with no more than ten members, but it expanded over the subsequent decades and now consists of nearly one hundred research members with tenure. The continuous growth of the DPRI to serve societal needs for natural disaster mitigation is something that we can be proud of and, as the DPRI's director, I do thank our predecessors and seniors for their unceasing efforts to secure this growth.



Figure 11. I served as Director of DPRI between 2011 and 2013. A ceremony and party to commemorate the sixtieth anniversary of DPRI was held in November 2012. The picture is Nakashima at DPRI's Director Office.

4.3 Presidency of Architectural Institute of Japan (AIJ)

My term as the DPRI director ended in March 2013. My third experience as a manager is the presidency of the AIJ. I was elected as its fifty-fourth president in June 2015. Since my inauguration, I have campaigned on behalf of the "Need for Uniting the Voice of Japan's Architecture Community".

I, together with the vice-presidents, focus particularly on the following issues in addition to regular activities. The first area of focus has been review of the current medium-to-long-term plan of AIJ and the determination of the next medium-term action plan conducive to the continuance of AIJ. The new plan and associated action plan were released on April 1, 2016. The second area of focus is commemorating the one hundred thirtieth anniversary of the AIJ and organizing various activities to celebrate this occasion. The third area is the promotion of gender equality in the discipline of architecture, taking note of a 30 to 40% ratio of female students. Japanese architecture outperforms

other engineering disciplines, where the ratio remains at just 10%. To this end, AIJ women's associations were established in each of nine regional branches of AIJ. The fourth area of focus is promoting the dissemination of the AIJ's academic outcomes on a global basis and preparing a new AIJ journal to be published in English. The last focus is to nurture young generations so that they become more global-minded and more interested in interactions with other regions and countries. These efforts are led by the vice-presidents, namely, Professors Koji Tokimatsu, Mitsumasa Midorikawa, Shuichi Matumura, Messors Koji Kodama, Shigeki Kuriyama and Fumio Nohara, to whom I am very grateful.

5. Professional Service

5.1 Activities in Learned Societies (Domestic)

Over the past three decades I have engaged in various activities with our learned and professional societies. My most extensive commitments are with the Architectural Institute of Japan (AIJ), and I was engaged in AIJ research committees particularly on steel structures, editorial committees for journals published by the AIJ, honors committees for nomination of awards and medals bestowed by the AIJ, and management boards as auditor, vice-president, and president. The AIJ Structure Committee is the oldest and largest research committee in the AIJ. It was founded in 1946, and I was the fifteenth chair of this committee. The committee consists of thirteen steering committees and about 150 sub-committees, in which over 2,000 members participate. This committee regularly publishes and updates a variety of design specifications and guidelines that have been used extensively in day-to-day structural design practice in Japan. During my tenure as chair, the committee has published twenty-three specifications and guidelines. In addition to the AIJ, I was involved in societies such as the Japanese Society for Steel Construction (JSSC) and the Japan Association for Earthquake Engineering (JAEE).

In 1999, the Japan Accreditation Board for Engineering Education (JABEE, equivalent to ABET in the United States) was established in Japan for the quality control and assurance of

engineering education in Japanese universities. In 2005, JABEE joined the Washington Accord, an international agreement among bodies responsible for accrediting engineering degree programs. From 2002 to 2006, I served as the founding chair of JABEE's review panel of the Architecture and Building Engineering Program and was engaged in the establishment of review procedures exercised by the panel.

5.2 Activities in Learned Societies (Overseas)

Thanks to my many friends overseas, I also became involved in the management of overseas academic societies, including my appointment as Director of the Earthquake Engineering Research Institute (EERI) of the United States. I had the fortune to be elected as a board member, and served on the board for three years. The president of EERI was Dr. Farzad Naeim, a prominent structural engineer who held the position of vice-president at John A. Martin & Associates. He was also a licensed lawyer in California. Joining the board led by his very unique and charming personality taught me much about the operation and running of US professional societies, which was very helpful in my own operation as the AIJ president.

In the fall of 2014, I assumed the position of executive vice-president of the International Association for Earthquake Engineering (IAEE), and, in the beginning of 2017, was promoted to the position of IAEE president-elect. This society was born in 1952 and has been a leading organization in earthquake engineering, host of the World Conference on Earthquake Engineering (WCEE). I learned from the IAEE history book that the late Professor Kiyoshi Muto contributed to the establishment of this association, and that he himself served as the founding president of IAEE. Since that founding, Japan has contributed continuously to the progress of IAEE. I do my best to continue Japan's contribution and to transfer the legacy of Japanese contribution to the next generation engaged in the research and practice of earthquake engineering.

5.3 Activities in Government Committees

For the past twenty years, I have also served on councils and committees that advise the administration of the government of Japan. These

ministries include the Cabinet Office of Japan (CAO), the Ministry of Education, Culture, Sports, and Science and Technology (MEXT), the Ministry of Land, Infrastructure and Transport (MLIT), and the Ministry of Internal Affairs and Communications (MIC).

In 2013, I assumed the position of Policy Advisor (in charge of science and technology) of CAO. CAO launched a new project, starting in 2014 and with an annual budget of over 300 million US dollars, on acceleration of technology innovation that will contribute to the strengthening of the Japanese society and economy. Ten thrust areas were selected, and, I was chosen as Program Director to lead a project whose focus is "strengthening national resilience against natural disasters". The project consists of three components essential to natural disaster prevention and mitigation, i.e., prediction, prevention, and response, covering such subjects as inundation by tsunami, heavy rains and tornados, liquefaction, real-time damage estimates, collection and sharing of disaster-related information, quasi-real time damage overview, securing communications in emergencies, and dissemination and sharing of disaster-related information to local governments and municipalities. The project is to continue for five years with an annual budget of over 20 million US dollars. Through this directorship, I am accumulating knowledge about the difficulties in communication among national ministries, the differences in mentality between people engaged in earthquake-related disasters and those in climate-related disasters, and other matters.

As a lesson learned from the 1995 Kobe earthquake, the Headquarters for Earthquake Research Promotion was established in MEXT, with the Minister of MEXT as the chair. The headquarters has two committees, one the Policy Committee and the other the Earthquake Research Committee. The Policy Committee is in charge of overseeing the government's budget appropriation on earthquake occurrences and forecasting, and advises on measures to be taken by ministries and other government agencies. The annual budget of the Japanese government for the related research and survey is a few hundred million US dollars. In 2012, I assumed the position of chair of the Policy Committee. Since beginning this work, I have tried

to bring together the earth science community and the earthquake engineering community, in the belief that frequent and friendly communication among those communities is the key to enhance disaster mitigation.

MILT has multiple councils that supervise legislative measures implemented by MILT. One of the councils is devoted to buildings and associated infrastructural systems, and also has overview on the constitution and amendment of associated building laws and notifications. I joined the council in 2012. I continue to learn how laws and regulations are established, and how government officials view the roles and duties of MILT with respect to building construction and maintenance.

5.4 Editorship in Academic Journals

The International Journal of Earthquake Engineering and Structural Dynamics (EESD) was founded in 1972 and has been the most highly regarded journal in the field of earthquake engineering research. Since 2004, I have served as Editor of the journal, together with Professor Anil Chopra of UC Berkeley (as Executive Editor) and Professor Peter Fajfar of University of Ljubljana (as Editor). Professor Fajfar was replaced by Professor Michael Fardis of University of Patras (as Editor) in January 2016. This editorship has been a unique experience for me. I was able to learn, through discussion with reviewers, what characteristics a good review should have. Too short a review is useless; too long and too detailed a review is cumbersome; there is a range of the right amount of description as a message to the authors.

In the past few years, I have noticed rapid changes in the business of publications of technical papers. Universities and academic institutions all over the world place more and more emphasis on the number and quality of technical papers that are published by their faculty members and researchers, and here the terms like “impact factor” and “h-index” are becoming very common. The researchers are asked to write more papers in more qualified journals (those with higher impact factors). As a consequence of this trend, many journals, including the EESD, receive more papers than before. The number of papers submitted to the EESD was in the range of about 200 ten years ago;

now it has increased to over 500. Unfortunately, the quality of those submitted papers keeps decreasing. It makes some sense because not a few researchers intentionally slice a decent-looking accomplishment, worthy of one paper, into multiple small subjects and submit each slice as a single paper. This is because of the pressure to publish more papers. I trust that such a practice eventually leads to the demise of our profession. Nonetheless, it continues to intensify – I may become too old by now.....

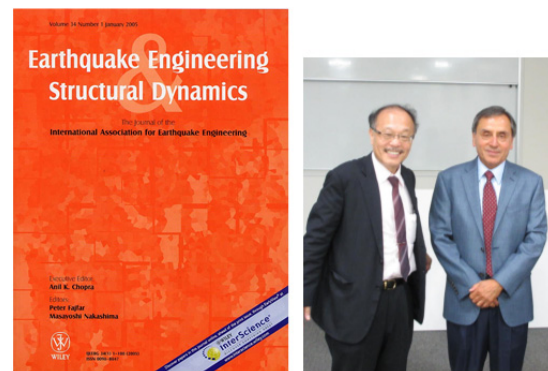

Figure 12. Since 2004, I serve aa Editor of Journal of Earthquake Engineering and Structural Dynamics (EESD), published by Wiley. I thank Professor Anil Chopra of UC Berkeley, Executive Editor of EESD for his great mentorship and advice for the running of academic journals.

5.5 Lectures

I have had the honor to be invited to deliver keynote and special lectures by various international conferences and academic institutions. A partial list of my invited lectures is shown in Section 4.6. Among those lectures, the following three presentations/lectures are most memorable: the UC Berkeley – CUREE Symposium in Honor of Ray Clough and Joseph Penzien, the Newmark Distinguished Lecture, and the Fazlur Rahman Khan Lecture.

The UC Berkeley – CUREE Symposium was held in Berkeley in 2002. I was one of about twenty guest speakers (out of those two from Japan) and spoke about the great contribution of Professors Clough and Penzien in the advancement of US-Japan joint research on earthquake engineering. Very fortunately, my speech came off well with

many humorous interludes, and I received ovations from the audience. After my speech, Professor Penzien kindly came to me and said: “Masayoshi, you are the highlight of the day.” Figure 13 is my personal copy of a legendary textbook, entitled “Dynamics of Structures”, written by Professors Clough and Penzien. In 1984 when Professor Clough visited Japan, I escorted him from Tsukuba to Tokyo. During the short trip, Professor Clough kindly gave his signature with comments in my book. During the 2002 Symposium, I received the signature with comments from Professor Penzien. I know that many senior people like me still own their personal copies of this legendary book, but mine, with actual signatures by the authors, is something that I am very proud of.

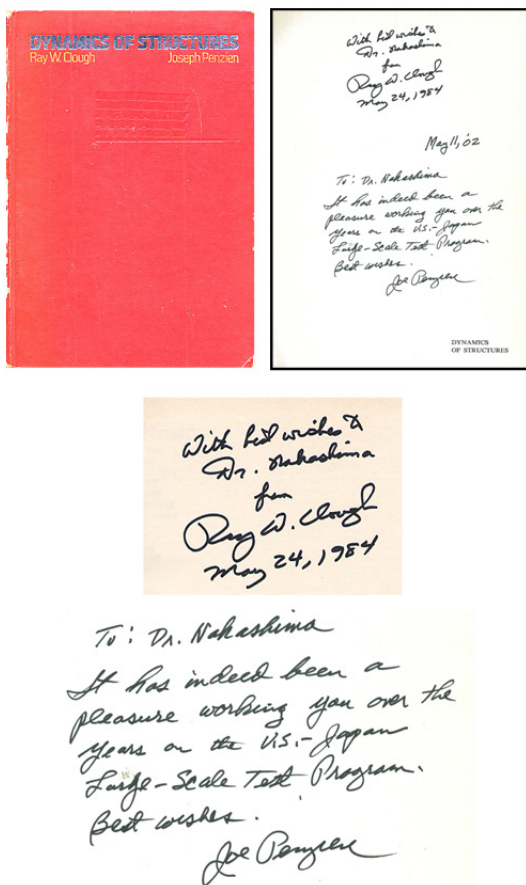

Figure 13. Nakashima’s personal copy of Dynamics of Structures, written by Professors Clough and Penzien, notable is the own signatures and comments by the authors at the back of the coverage.

In 2006, I received a message from an old friend of mine, Professor Dan Abrams of the University of

Illinois at Urbana/Champaign (UIUC), inviting me to serve as the Newmark distinguished lecturer. It was a high honor for me, and I accepted the invitation to make my presentation at UIUC. I spoke about the post-Kobe activities, including the running of E-Defense, and the event was well-attended. I also met and engaged in discussion with many young faculty members in the department. I also met with quite a few old friends there, like Professors Amr Elnashai, Bill Spencer, and Jerry Hajjar, whose presence reconfirmed the strength of UIUC in structural engineering.

In 2010, another old friend of mine, Professor Dan Frangopol, sent a message to me inviting me to deliver the Fazlur Rahman Khan Lecture sponsored by Lehigh University. As many of you know, a Lehigh professor, the late Lynn S. Beelde, led the Council on Tall Buildings and Urban Habitat (CTBUH) for many years. The Lecture was established to honor Dr. Fazlur Khan who significantly contributed to CTBUH, and the lectureship is implemented by Lehigh University under Professor Frangopol who holds the position of Fazlur Khan Chair. As Lehigh is my Alma Mater, there was every reason to accept the invitation. In 2011, I spoke in front of a large audience, describing the notable Japanese activities after the 1995 Kobe and 2011 Tohoku earthquakes. Very fortuitously, Mrs. Lynne Beedle, the widow of Professor Lynne Beedle, attended my lecture, and I was able to introduce myself to her and tell her my sincere gratitude to Professor Beedle. I was also able to meet, chat, and dine with my mentor, Professor Le-Wu Lu. During 1970s and 1980s, he was a frequent visitor to Japan, and he has many Japanese friends. I reported to him how his old friends are doing now, and how the US-Japan joint research has continued. He looked happy to hear my reports. Unfortunately, he lost his health and passed away in 2013. The conversation with Professor Lu was my last one with him.

6. Closure

I retired from Kyoto University on March 31, 2017. For this occasion, my former students and post-docs have kindly worked on the publication of a memory book that describes my four decades of

life in education and research. I wanted to document my public life to express my sincere appreciations to my teachers, mentors, colleagues, and friends around the world, and also to transfer some of the knowledge that I have accumulated over the decades to my former students, post-docs, and junior colleagues.

The memory book consists of four chapters. In Chapter 1, “Retrospect”, I give an overview of my public life chronologically from my student days at Kyoto University to my professorship at the Disaster Prevention Research Institute (DPRI) at Kyoto University. This is followed by a summary of the research subjects that I engaged with my students and colleagues. The chapter also summarizes my life as an educator and as an administrator. Chapter 2 is the highlight of the book, comprising messages from my mentors, colleagues and friends, and students and those who spent an extended period in my research group. Very fortunately, the chapter contains a total of 294 messages. Chapter 3 is a summary of my exterritorial activities, and Chapter 4 is a series of records regarding my research and associated activities.

The title of this memory book is named “The Flow of Time – Part 2”. Its origin was a memory book published thirty-five years ago to commemorate the retirement of my teacher and mentor, the late Professor Minoru Wakabayashi. The title of his memory book was “Tokino-Nagare” whose English translation is “The Flow of Time” or “Time Flows”. A copy of the book is still sitting in a bookshelf of the student room in my group, and my current students occasionally browse the copy. They report to me that the book is moving as they learn the roots of the research group that they have been joining and they see the faces of legendary researchers around the world. These words from my students confirm me in my desire to contribute my own history to this legacy. In appreciation of my luck in inheriting the spirit and fraternity of Professor Wakabayashi’s group, and as an expression of my gratitude to my predecessor, I decided to inherit the title of Professor Wakabayashi’s memory book, with an added subtitle of “Part 2”. Use of this title was generously endorsed by two of the most senior members of Professor Wakabayashi’s group,

Professors Chiaki Matsui (Kyushu University) and Bunzo Tsuji (Kyoto University).

This article of mine to be published in DPRI’s Annuals is an excerpt of my memory book, primarily focusing on my history of research, education, and management. Before the closure of this article, my sincere gratitude is extended to the members of the team that was formed to complete this book as well as to organize other activities to commemorate my retirement. The team consists of many former students and post-docs who used to be working in my research group. Naturally, they are all busy with their respective professional activities, but they kindly spent many hours to realize the publication of this book. I am very happy to find myself surrounded by those people.

References

- He, L., Togo, T., Hayashi, K., Kurata, M., and Nakashima, M., “Cyclic Behavior of Multirow Slit Shear Walls Made from Low-Yield-Point Steel”, *Journal of Structural Engineering*, ASCE, Vol.142, No.11, November 2016, .
- Hsiao, P-C., Hayashi, K., Inamasu, H., Luo, Y., and Nakashima, M., “Development and Testing of Naturally Buckling Steel Braces, *Journal of Structural Engineering* Januray, Vol. 142, No. 1, 2016.
- Inamasu, H., Skalomenos, K., Hsiao, P-C., Hayashi, K., Kurata, M., and Nakashima, M., “Gusset Plate Connections for Naturally Buckling Braces, *Journal of Structural Engineering*, ASCE, Vol.143, No.8, August 2017, pp.04017065-1-04017065-10.
- Kurata, M., He, L., and Nakashima, M., “Steel Slit Shear Walls with Double-tapered Links Capable of Condition Assessment”, *Journal of Earthquake Engineering and Structural Dynamics*, Vol.44, No.8, July 2015, pp.1271–1287.
- Nakashima, M., Ishida, M., and Ando, K., “Integration Techniques for Substructure Pseudo Dynamic Test (Pseudo dynamic test using substructuring techniques),” *Journal of Structural and Construction Engineering*, Architectural Institute of Japan, No.417, November 1990, pp.107-117 (in Japanese),

- Nakashima, M., Akazawa, T., and Igarashi, H., "Pseudo Dynamic Testing Using Conventional Testing Devices", *Journal of Earthquake Engineering and Structural Dynamics*, John Wiley & Sons Ltd., Vol.24, No.10, October 1995, pp.1409-1422.
- Nakashima, M., Akazawa, T., and Tsuji, B., "Strain-Hardening Behavior of Shear Panels Made of Low Yield Steel, II: Model", *Journal of Structural Engineering*, ASCE, Vol.121, No.12, December 1995, pp.1750-1757.
- Nakashima, M. and Kato, H., "Part 3, Experimental Error Growth of Pseudo Dynamic Testing (Stability and Accuracy Behavior of Pseudo Dynamic Response)", *Journal of Structural and Construction Engineering*, Architectural Institute of Japan, No.386, November 1988, pp.36-48.
- Nakashima, M. and Kato, H., "Part 4, Control of Experimental Error Growth of Pseudo Dynamic Testing (Stability and Accuracy Behavior of Pseudo Dynamic Response)", *Journal of Structural and Construction Engineering*, Architectural Institute of Japan, No.401, July 1989, pp.129-138.
- Nakashima, M., et al., "Integration Techniques for Substructure Pseudo Dynamic Test," *Proceedings of the Fourth U.S. National Conference on Earthquake Engineering*, Palm Springs, USA, May 20-24, 1990, Vol.2, pp.515-524.
- Nakashima, M., Kato, H., and Takaoka, E., "Development of Real-Time Pseudo Dynamic Testing", *Journal of Earthquake Engineering and Structural Dynamics*, Vol.21, No.1, 1992, pp.79-92.
- Nakashima, M. and Masaoka, N., "Real-time Online Test for MDOF Systems", *Journal of Earthquake Engineering and Structural Dynamics*, Vol.28, No.4, April 1999, pp.393-420.
- Nakashima, M., "Strain-Hardening Behavior of Shear Panels Made of Low Yield Steel, I: Test", *Journal of Structural Engineering*, ASCE, Vol.121, No.12, December 1995, pp.1742-1749.
- Nakashima, M., Suita, K., Morisako, K., and Maruoka, Y., "Tests of Welded Beam-Column Subassemblies I: Global Behavior", *Journal of Structural Engineering*, ASCE, Vol.124, No.11, 1998, pp.1236-1244.
- Sato, E., Furukawa, S., Kakehi, A., and Nakashima, M., "Full-Scale Shaking Table Test for Examination of Safety and Functionality of Base-Isolated Medical Facilities", *Journal of Earthquake Engineering and Structural Dynamics*, Vol.40, No. 6, June 2011, pp.1435-1453.
- Shi, Y., Becker, T. C., Furukawa, S., Sato, E., and Nakashima, M., "LQR Control with Frequency-Dependent Scheduled Gain for a Semi-active Floor Isolation System", *Journal of Earthquake Engineering and Structural Dynamics*, Vol.43, July 2014, pp.1265-1284.
- Shi, Y., Kurata, M., and Nakashima M., "Disorder and Damage of Base-Isolated Medical Facilities When Subjected to Near-Fault and Long-Period Ground Motions", *Journal of Earthquake Engineering and Structural Dynamics*, Vol.43, No.11, September, 2014, pp.1683-1701.
- Skalomenos, A. K., Inamasu, H., Shimada, H., and Nakashima, M., "Development of a Steel Brace with Intentional Eccentricity and Experimental Validation", *Journal of Structural Engineering*, ASCE, Vol.143, No.8, August 2017, pp.04017072-1-04017072-13.
- Suita, K., Nakashima, M., and Morisako, K., "Tests of Welded Beam-Column Subassemblies II: Detailed Behavior", *Journal of Structural Engineering*, ASCE, Vol.124, No.11, 1998, pp.1245-1252.
- Yamazaki, Y., Nakashima, M., and Kaminosono, T., "Reliability of Pseudo Dynamic Test in Earthquake Response Simulation", *Journal of Structural Engineering*, ASCE, Vol.115, No.8, August 1989, pp.2098-2112.

(Received July 16, 2017)